

**SMART**  
MACHINE TOOL

**SM1682-50/  
2082-50**

**40T/60T MAGAZINE**

**Installation  
Packet**

# 40T MAGAZINE

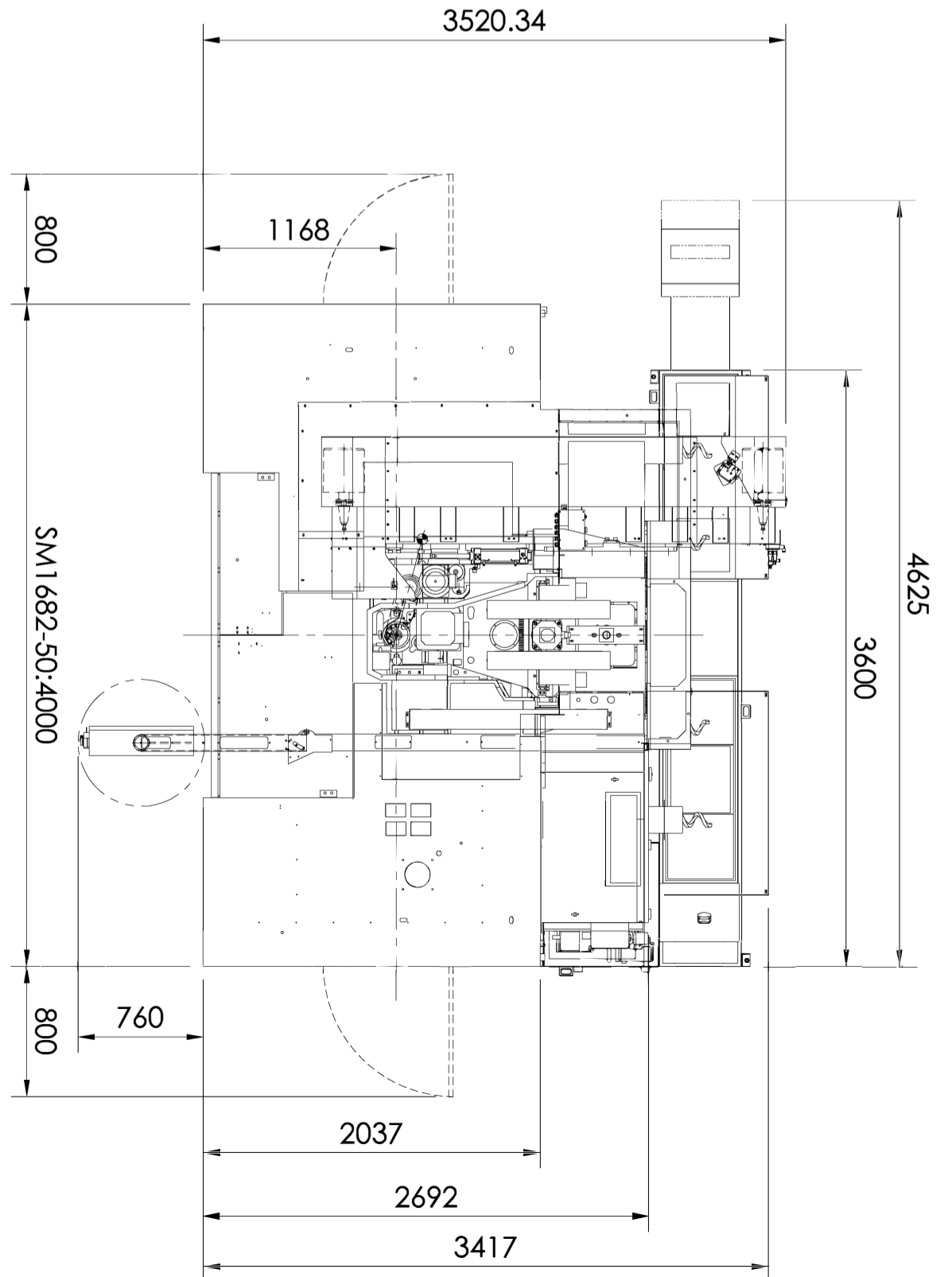
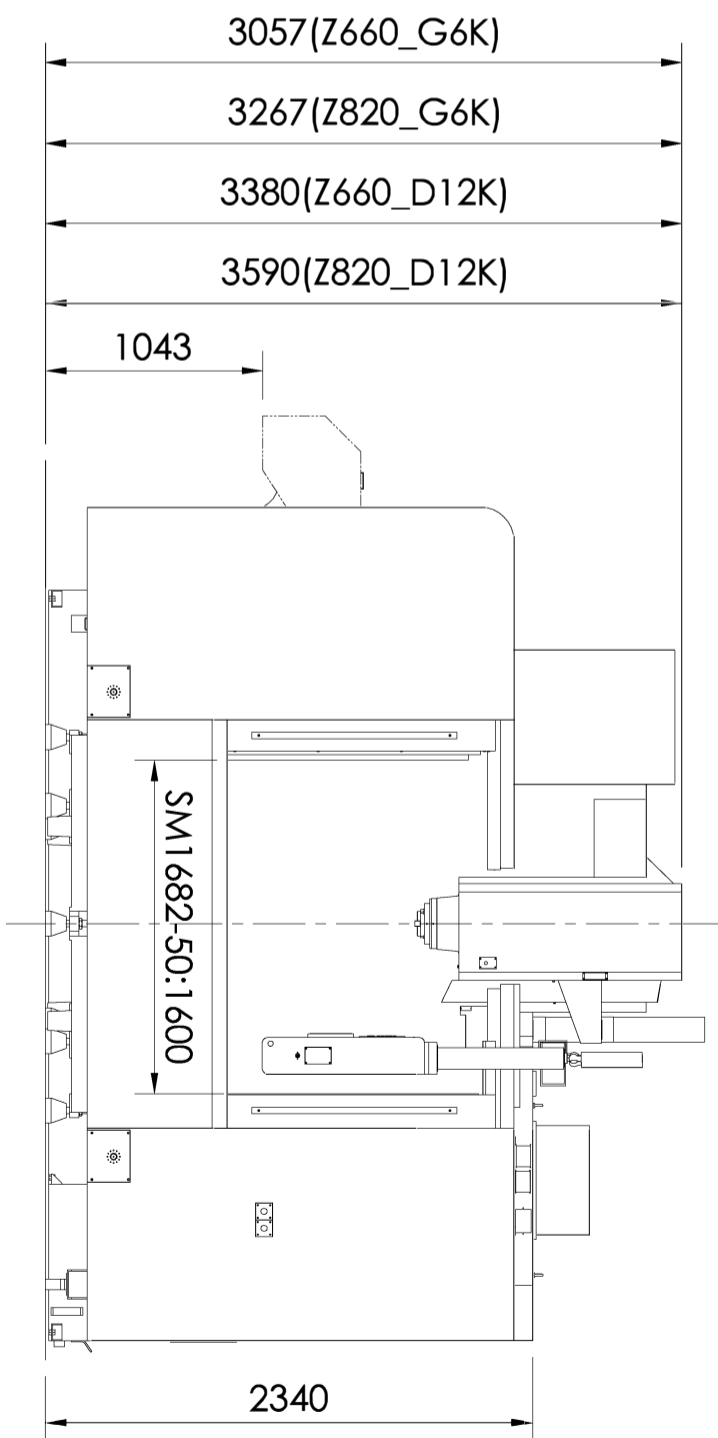
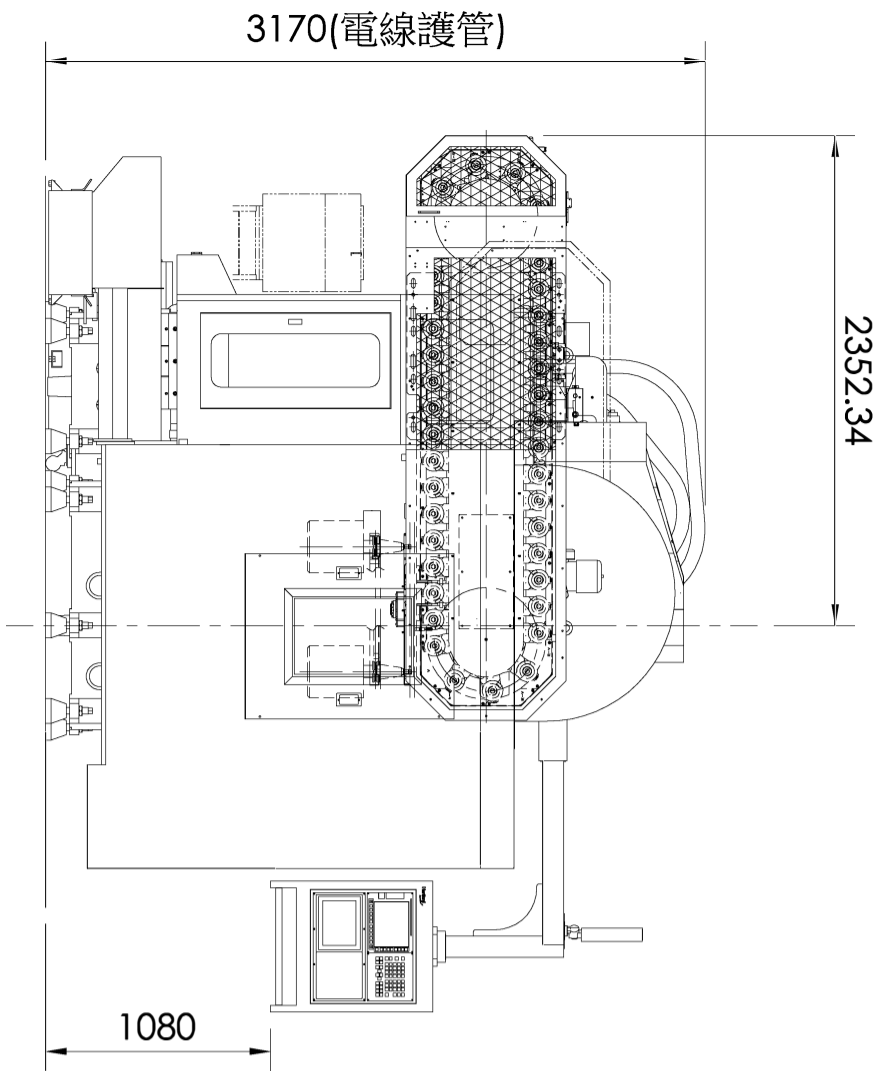

# 60T MAGAZINE

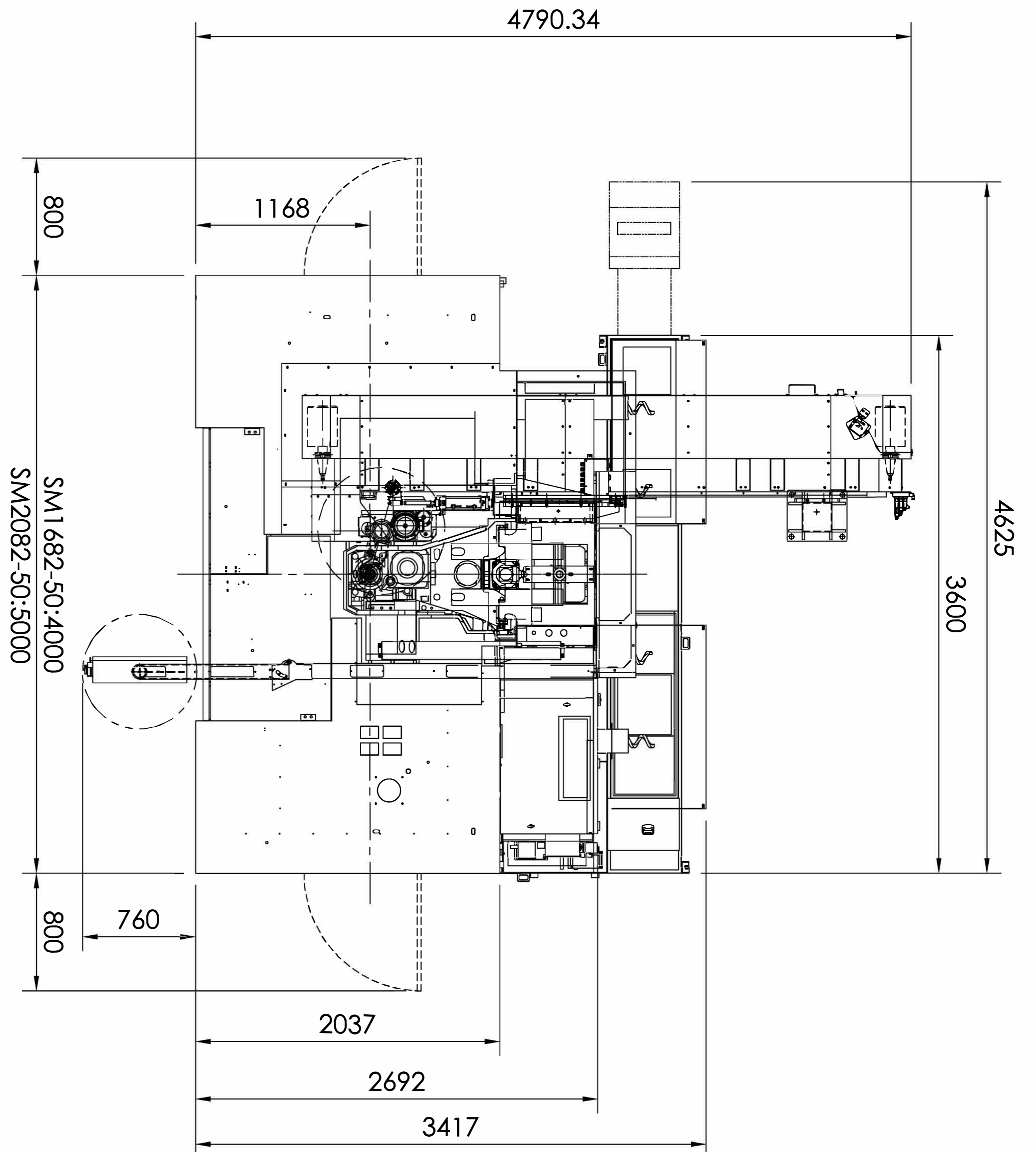
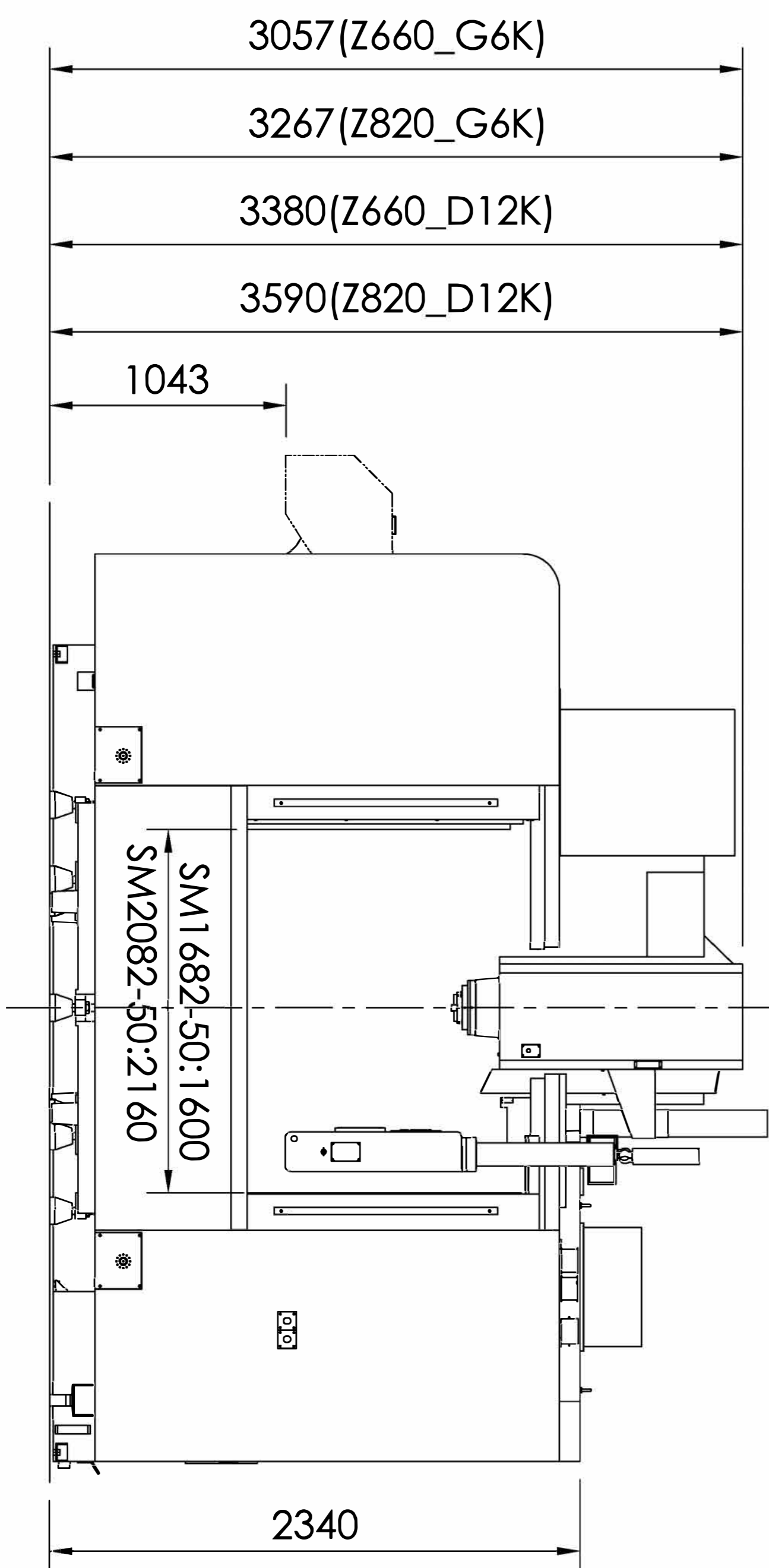
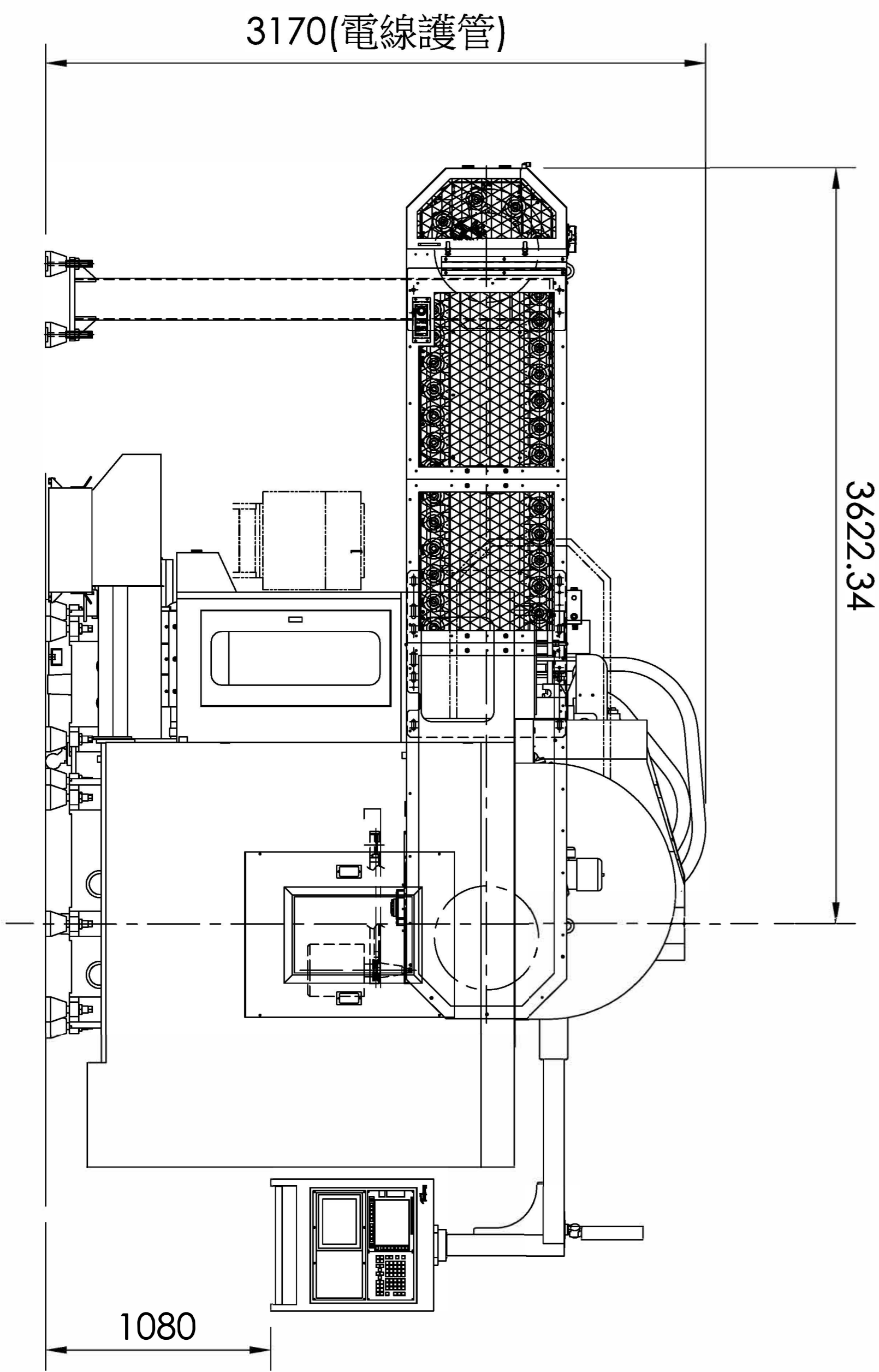

## SM1682 Foundation and table Diagram

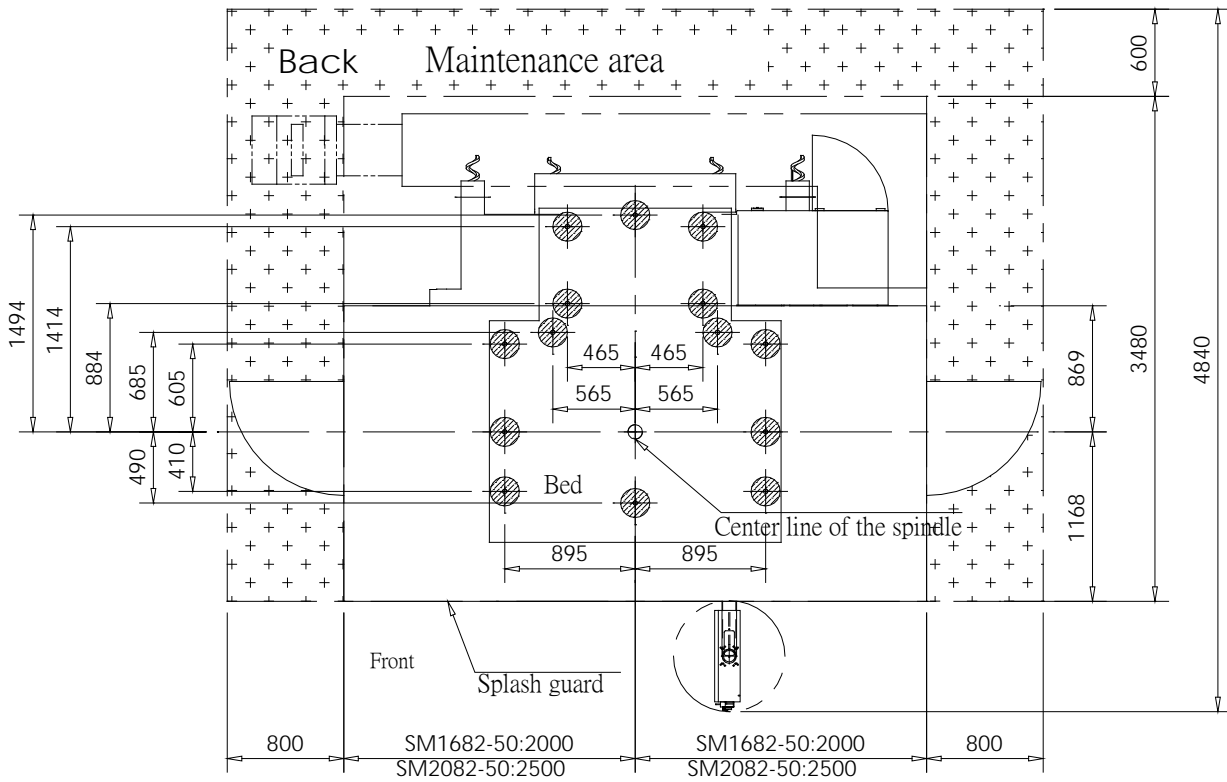

Model	面積尺寸 Working Surface (mm)	最大載重 Max. Table Load (kg)	T 型槽間距數量 T-Slot (Number*Pitc h)	T 型槽尺寸 T-Slot Size (mm)
SM1682-50	1750*820	2200	150*5	18
SM2082-50	2150*820	2600	150*5	18

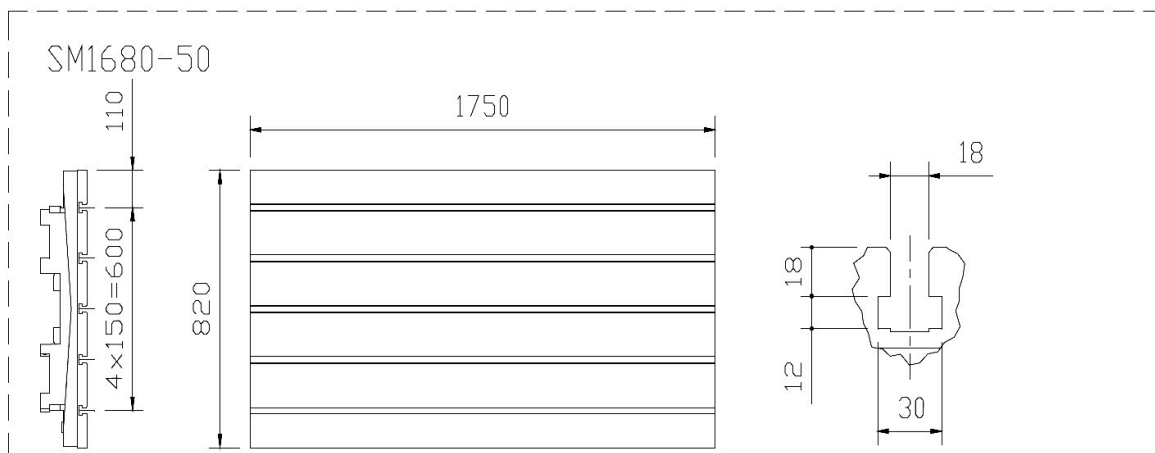

Required air pressure	psi	95
Electrical Power consumption	KVA	50T=55 40T=40
	Amps @220 V	50T=144 40T=104
Voltage		220V +/- 10%

## Oil Inlet 注油點位置

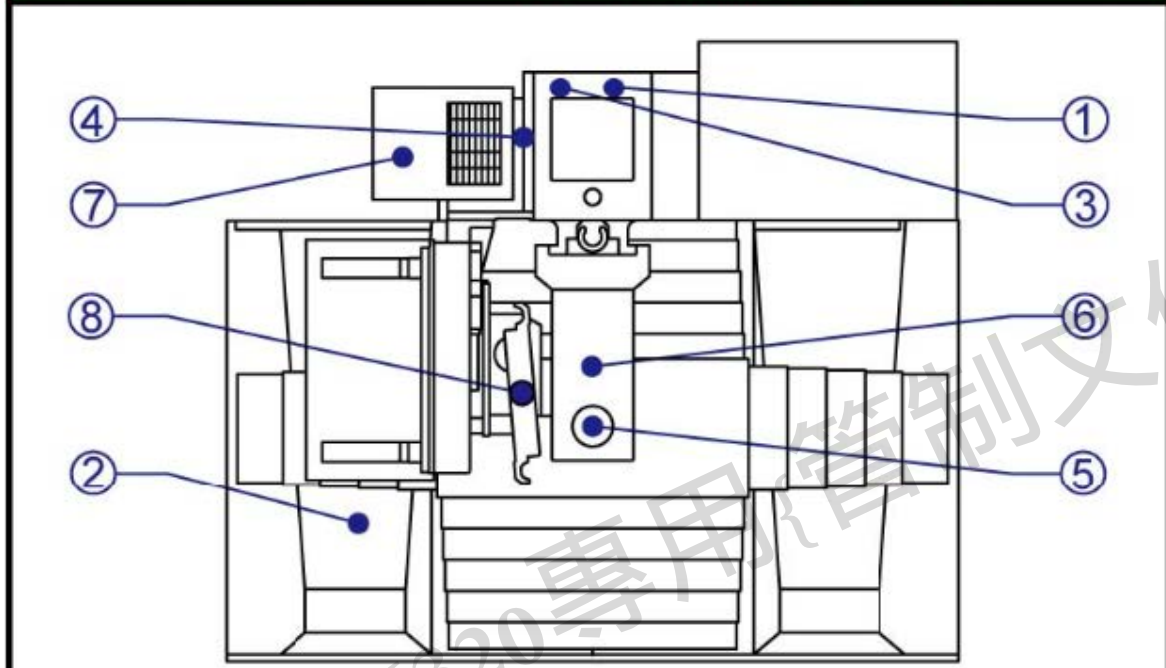

8112000024

No.	Replenishing Point	Oil Type	Oiling Period	Oiling Method
1	Air Regulator	ISO-VG 32	Check every day	Fill oil to upper limit of oil gauge
2	Coolant Tank Required at install	Customer Preference 115 gallons	Warning Alarms	
3	Oil Lubricator	ISO-VG 68		
4 (OP.)	Oil Air Lubricator	ISO-VG 32	Check every 3 month	
5	Booster Cylinder	ISO-VG 32		
6 (OP.)	Gearbox of Head REQUIRED AT INSTALL	ISO-VG 32 5 Gallons	Check every day	Fill oil to upper limit of oil gauge. (Change every 6 month to one year.)
7 (OP.)	Spindle Oil Cooler (P.D)	ISO-VG 10		
8 (OP.)	ARM Mechanism ATC	ISO-VG 150		



#40

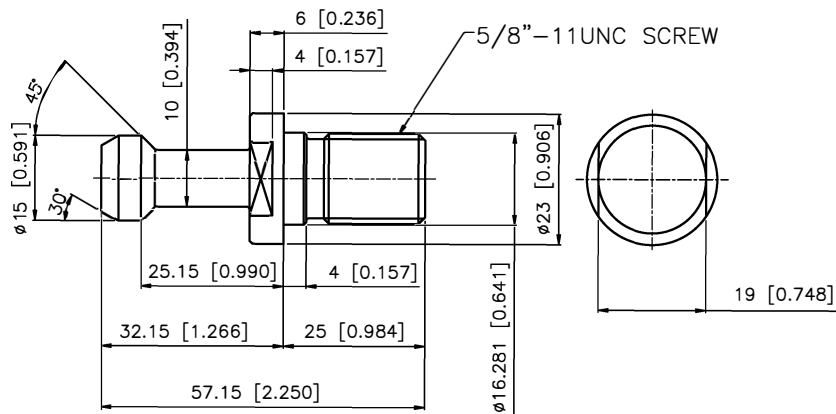

Lyndex PN  
Non CTS  
C40-4500  
CTS  
C40-4500H

#50  
P50T-1

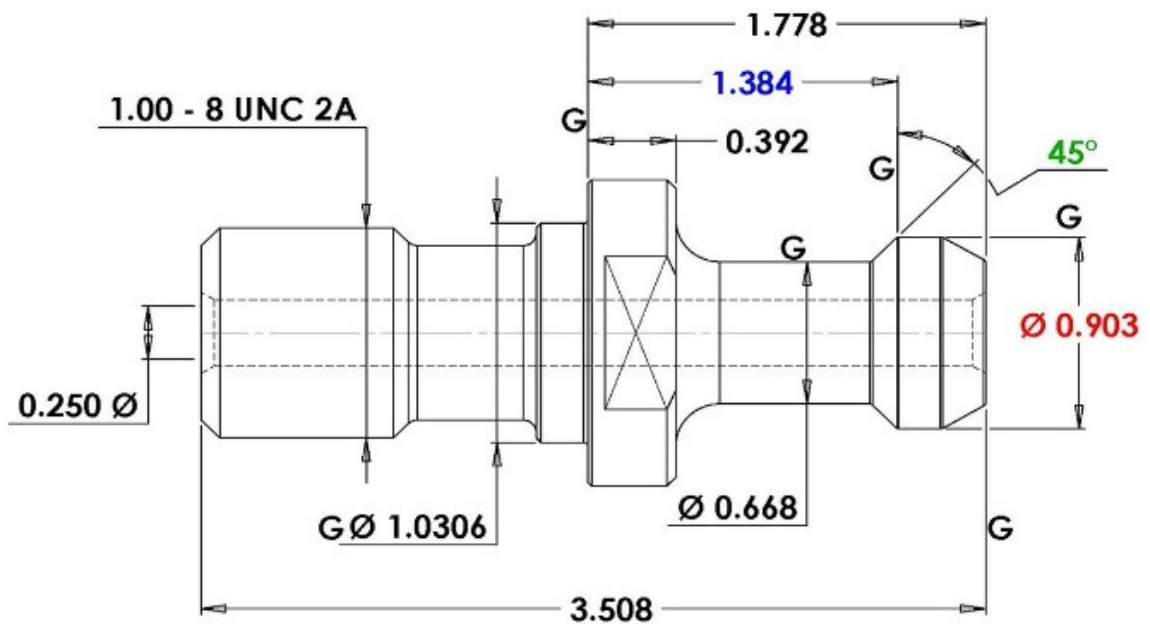

Trucking dimensions	
SM1050	146" x 91 x 101 @ 12,538
Accessories	156" x 46 x 79 @ 983
SM1100	146" x 91 x 101 @ 17,518
Accessories	156 x 46 x 79 @ 3,097
SM1370	: 142" x 92 x 101 @ 18,801
Accessories	177 x 46 x 79 @ 4,583
SM1570	146 x 91 x 101 @ 19,731
Accessories	191 x 91 x 79 @ 3,536
Accessories	157 x 91 x 79 @ 2,465
SM1682	181" x 150" x 148" 31,350lbs
SM2082	209" x 150" x 148" 34,613 lbs
SW216	445" x 164 x 158 @ 59,305
SW316	445" x 164 x 158 @ 66,668
HSA316	445" x 164 x 158 @ 64,199