

SMART
MACHINE TOOL

NL 6000

**Installation
Packet**

0001000001A00

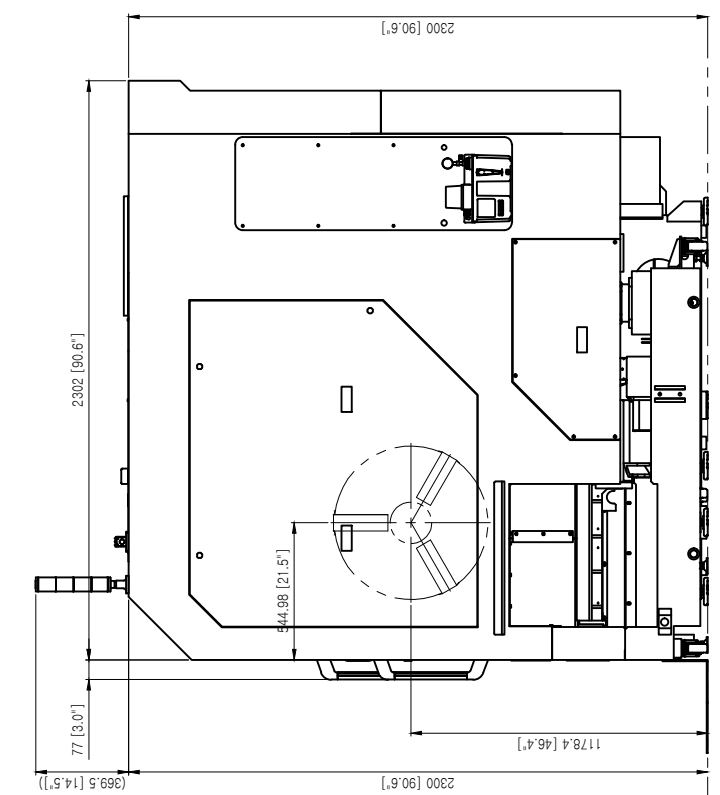
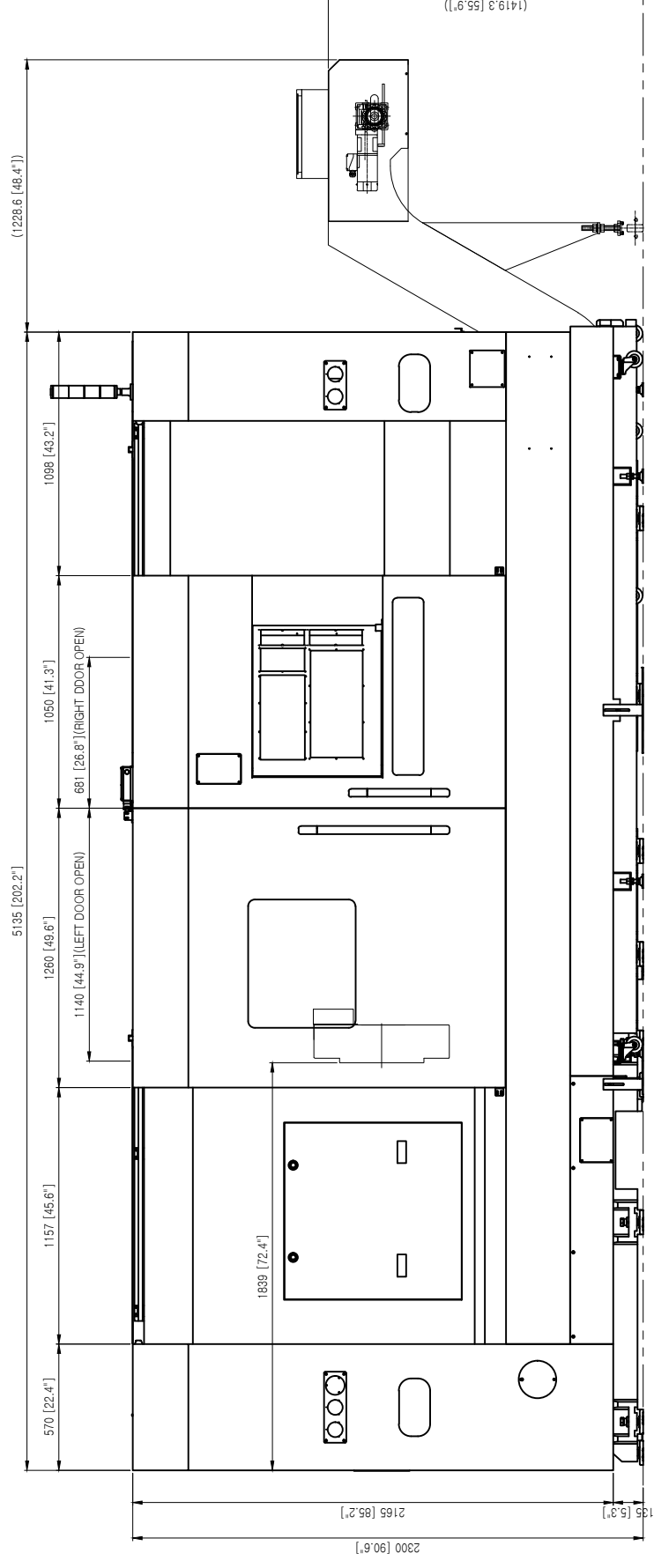
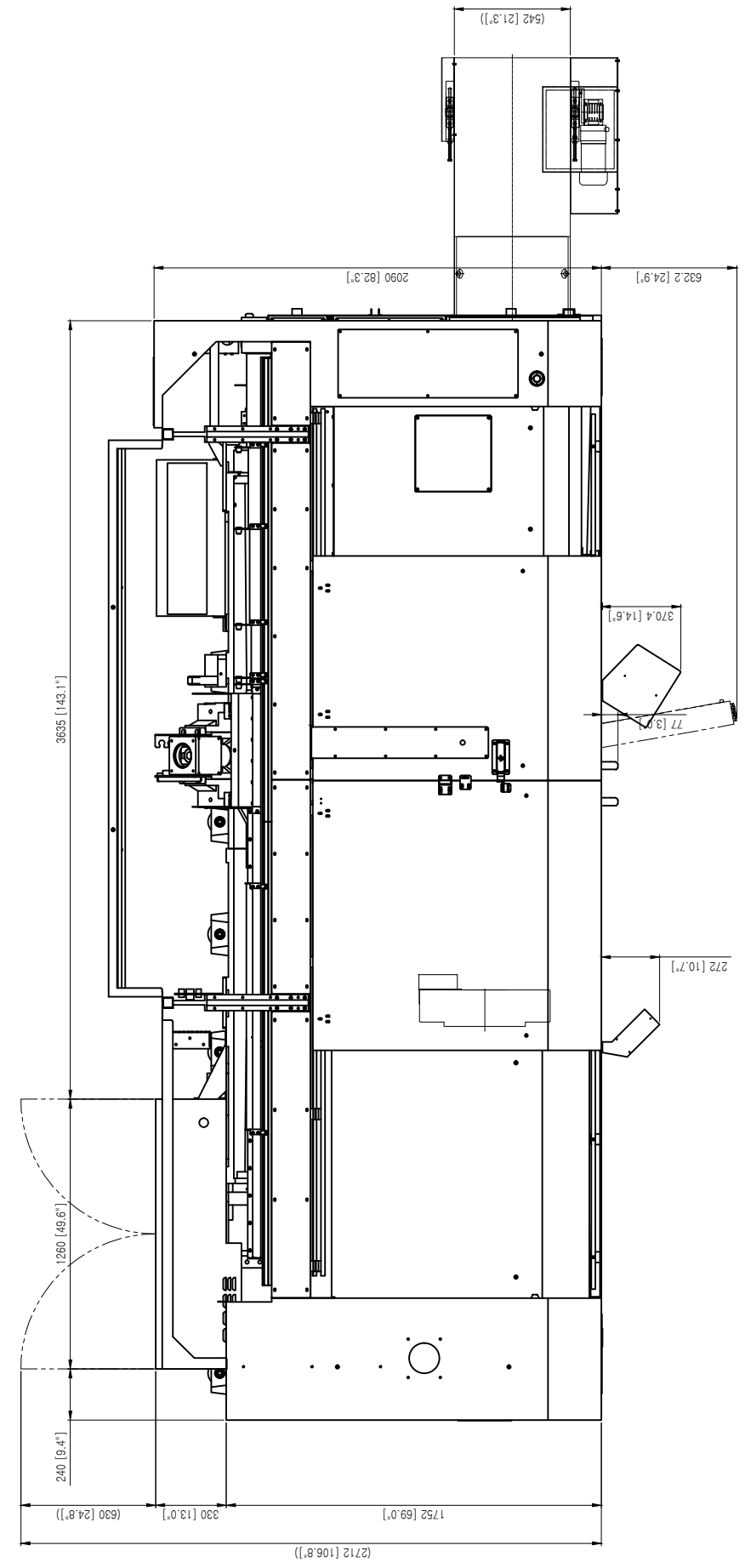

주요

- 1. 단위 : mm [inch]
- 2. 상기 사항은 품질 향상등을 위하여 예고없이 변경 될 수 있음.

APP'D	J. W. SHIN	GENERAL TOLERANCE	HEAT TREATMENT	WEIGHT	SMTK		
	19.07.19	0.5- 6 ± 0.1		KG			
REV'D		6-30 ± 0.2 30-120 ± 0.3 120-315 ± 0.5			UNIT ASS'Y	LAYER-LAY-OUT	
CHE'D		315-1000 ± 0.8 1000-2000 ± 1.2	MATERIAL		NAME	GENERAL LAY-OUT	
DES'D	J. S. PARK	LESS DIFFERENCE	PLATING	1/12		SCALE	
DATE	19.07.19	CHAMFER & CONNER CO. 3. RD. B				1/12	
N 6000001 A00 1/1							

NO	REV'D	CHE'D	DATE	REVISION

Packing Information (Update date: 2024-02-23)

NO.	Model	Model (Short)	Description	PART NAME	CBM	NET WEIGHT (KGS)	PACKING WEIGHT (KGS)	GROSS WEIGHT (KGS)
1	NL1500/2000/2000B (USA only)	NL1500/2000/2000B	Machine	3,600(L) X 2,300(W) X 2,250(H)	18.63	3,900	530	4,430
2	NL1500M/2000M/2000BM (USA only)	NL1500M/2000M/2000BM	Machine	3,600(L) X 2,300(W) X 2,250(H)	18.63	4,200	530	4,730
3	NL2000ASY	NL2000ASY	Machine + Chip conveyor	5,300(L) X 2,300(W) X 2,475(H)	30.17	5,700	700	6,400
4	NL2000BSY	NL2000BSY	Machine + Chip conveyor	5,300(L) X 2,300(W) X 2,475(H)	30.17	5,800	700	6,500
5	NL2500SY	NL2500SY	Machine + Chip conveyor	5,300(L) X 2,300(W) X 2,475(H)	30.17	6,100	700	6,800
6	NL2500/750	NL2500	Machine + Chip conveyor	5,100(L) X 2,300(W) X 2,250(H)	26.39	5,700	660	6,360
7	NL2500M/750	NL2500M	Machine + Chip conveyor	5,100(L) X 2,300(W) X 2,250(H)	26.39	5,900	660	6,560
8	NL2500/1100	NL2500L	Machine + Chip conveyor	5,550(L) X 2,300(W) X 2,250(H)	28.72	6,900	720	7,620
9	NL2500M/1100	NL2500LM	Machine + Chip conveyor	5,550(L) X 2,300(W) X 2,250(H)	28.72	7,100	720	7,820
10	NL3000B/750	NL3000B	Machine + Chip conveyor	5,100(L) X 2,300(W) X 2,250(H)	26.39	5,700	660	6,360
11	NL3000BM/750	NL3000BM	Machine + Chip conveyor	5,100(L) X 2,300(W) X 2,250(H)	26.39	5,900	660	6,560
12	NL3000B/1100	NL3000BL	Machine + Chip conveyor	5,550(L) X 2,300(W) X 2,250(H)	28.72	6,900	720	7,620
13	NL3000BM/1100	NL3000BLM	Machine + Chip conveyor	5,550(L) X 2,300(W) X 2,250(H)	28.72	7,100	720	7,820
14	NL4000M/1200	NL4000M	Machine	4,800(L) X 2,300(W) X 2,450(H)	27.05	10,800	650	11,450
15	NL4000/1200 C/C	NL4000 C/C	Chip conveyor	4,250(L) X 950(W) X 1,500(H)	6.06	800	70	870
16	NL4000M/2200	NL4000LM	Machine	6,000(L) X 2,300(W) X 2,450(H)	33.81	13,700	750	14,450
17	NL4000(M)/2200 C/C	NL4000L/LM C/C	Chip conveyor	5,450(L) X 950(W) X 1,600(H)	8.21	1,000	100	1,100
18	NL4000Y/2200	NL4000LY	Machine	6,000(L) X 2,300(W) X 2,950(H)	40.71	15,000	650	15,650
19	NL4000Y/2200 C/C	NL4000LY C/C	Chip conveyor	5,450(L) X 950(W) X 1,880(H)	9.73	1,000	100	1,100
20	NL4000(M)/3200	NL4000XL/XLM	Machine	7,000(L) X 2,300(W) X 2,550(H)	41.06	16,800	1,500	18,300
21	NL4000(M)/3200 C/C	NL4000XL/XLM C/C	Chip conveyor	6,450(L) X 1,150(W) X 1,600(H)	11.87	1,200	100	1,300
22	NL5000/1200	NL5000	Machine	4,800(L) X 2,300(W) X 2,450(H)	27.05	10,800	650	11,450
23	NL5000M/1200	NL5000M	Machine	4,800(L) X 2,300(W) X 2,450(H)	27.05	10,900	650	11,550
24	NL5000(M)/1200 C/C	NL5000/M C/C	Chip conveyor	4,250(L) X 950(W) X 1,500(H)	6.06	800	70	870
25	NL5000/2200	NL5000L	Machine	6,000(L) X 2,300(W) X 2,450(H)	33.81	13,700	750	14,450
26	NL5000M/2200	NL5000LM	Machine	6,000(L) X 2,300(W) X 2,450(H)	33.81	13,800	750	14,550
27	NL5000(M)/2200 C/C	NL5000L/LM C/C	Chip conveyor	5,450(L) X 950(W) X 1,600(H)	8.21	1,000	100	1,100
28	NL5000(M)/3200	NL5000XL/XLM	Machine	7,000(L) X 2,300(W) X 2,550(H)	41.06	16,900	1,500	18,400
29	NL5000(M)/3200 C/C	NL5000XL/XLM C/C	Chip conveyor	6,450(L) X 1,150(W) X 1,600(H)	11.87	1,200	100	1,300
30	NL6000/750(M) C/C	NL6000S/SM C/C	Chip conveyor + Rear cover	3,950(L) X 2,300(W) X 1,750(H)	15.90	1,800	130	1,930
31	NL6000(M)/1500 C/C	NL6000/M C/C	Chip conveyor + Rear cover	4,850(L) X 2,300(W) X 1,600(H)	17.85	2,150	150	2,300
32	NL6000(M)/2200 C/C	NL6000L/LM C/C	Chip conveyor + Rear cover	5,550(L) X 2,300(W) X 1,750(H)	22.34	2,250	250	2,500
33	NL6000(M)/3200 C/T	NL6000XL/XLM C/T	Coolant tank + Rear cover	5,600(L) X 2,300(W) X 950(H)	12.24	2,650	350	3,000
34	NV5500L C/C	NV5500L C/C	Chip conveyor	4,880(L) X 1,150(W) X 750(H)	4.21	900	100	1,000

MACHINE MODEL	KVA	AMPS @ 220V	Coolant	Slideways	Hyd. Unit	Transmission	Chuck	Oil for Air
NL150/200/250	31	82	48	.79 gal	5.3 gal	n/a	.2 oz daily	N/A
NL1500(M)	31	82	48	.79 gal	5.3 gal	n/a	.2 oz daily	.6 oz
NL2000(M)	31	82	48	.79 gal	5.3 gal	n/a	.2 oz daily	.6 oz
NL2000A/B/S/Y	40	105	60	.79 gal	5.3 gal	n/a	.2 oz daily	.6 oz
NL2500SY	50	131	60	.79 gal	5.3 gal	n/a	.2 oz daily	.6 oz
NL2500S	40	105	48	.79 gal	5.3 gal	0.75	.2 oz daily	.6 oz
NL2500(M)	40	105	53	.79 gal	5.3 gal	0.75	.2 oz daily	.6 oz
NL3000(M)	40	105	63	.79 gal	5.3 gal	0.75	.2 oz daily	N/A
NL4000(M)	55	144	63	.79 gal	6.4 gal	0.75	.2 oz daily	N/A
NL5000(M)	55	144	63	.79 gal	6.4 gal	0.75	.2 oz daily	N/A
NL5000L(M)	65	170	130	.79 gal	6.4 gal	0.75	.2 oz daily	N/A
NL6000(M)	65	170	105	.79 gal	15 gal	0.75	.2 oz daily	N/A
NL6000L(M)	65	170	150	.79 gal	15 gal	0.75	.2 oz daily	N/A
NL6000XL(M)	65	170	180	.79 gal	15 gal	0.75	.2 oz daily	N/A
NL7000L(M)	65	170	150	.79 gal	15 gal	2 gal	.2 oz daily	N/A
NL7000XL(M)	65	170	180	.79 gal	15 gal	2 gal	.2 oz daily	N/A
				Shell Oil T68	Mobil DTE 24	Mobil Oil Light	SW10	DTE Light
				Mobil Vactra#2		ISO VG 32		
				check daily	check daily	check daily	grease daily	check daily

Air requirements: 80-100 psi, 5-10 CFM

Coolant only fluid required at install

Voltage : 220V +/- 10%

NO.	DWG NO.	NAME	MAT'L	Q'TY	REMARK
15	N6090103A00	DRAW TUBE	STKM13C	1	
16	N6090102A00	CYLINDER BRACKET	SS400	1	
17	N6090801A00	HYD CHUCK		1	HCH-24A15(27T, M175x 3.0P)
18	S0210825	SOCKET HEAD BOLT		4	M8x25L
19	S2550800	SPRING WASHER		4	M8
20	N2590805A00	PROXIMITY SWITCH		2	FL7M-3J6HD-C(YAMATAKE)
21	S2530800	WASHER		4	M8
22	N5090804A00	SOFT JAW		2	SB18A2(SAMCHULLY)
23	N5090805A00	HARD JAW		1	HB18B2(SAMCHULLY)
24	N6090101A00	CHUCK SAFETY COVER	SPCC	1	
25	S0210612	SOCKET HEAD BOLT		3	M6x12L
26	S2550600	SPRING WASHER		3	M6
27	N5090803A00	ROTARY CYLINDER		1	SDL-30516(SAMCHULLY)
28	S0221216	SOCKET HEAD BOLT		12	M12x160L

00V1000900N
15090001A00

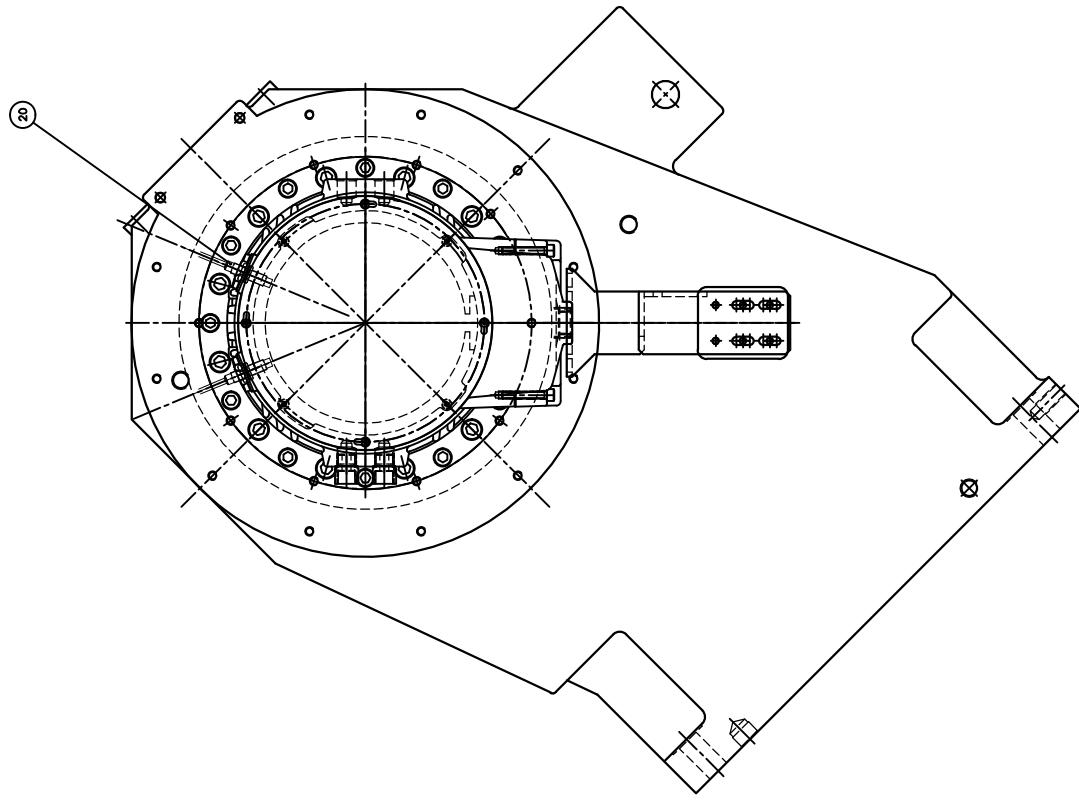
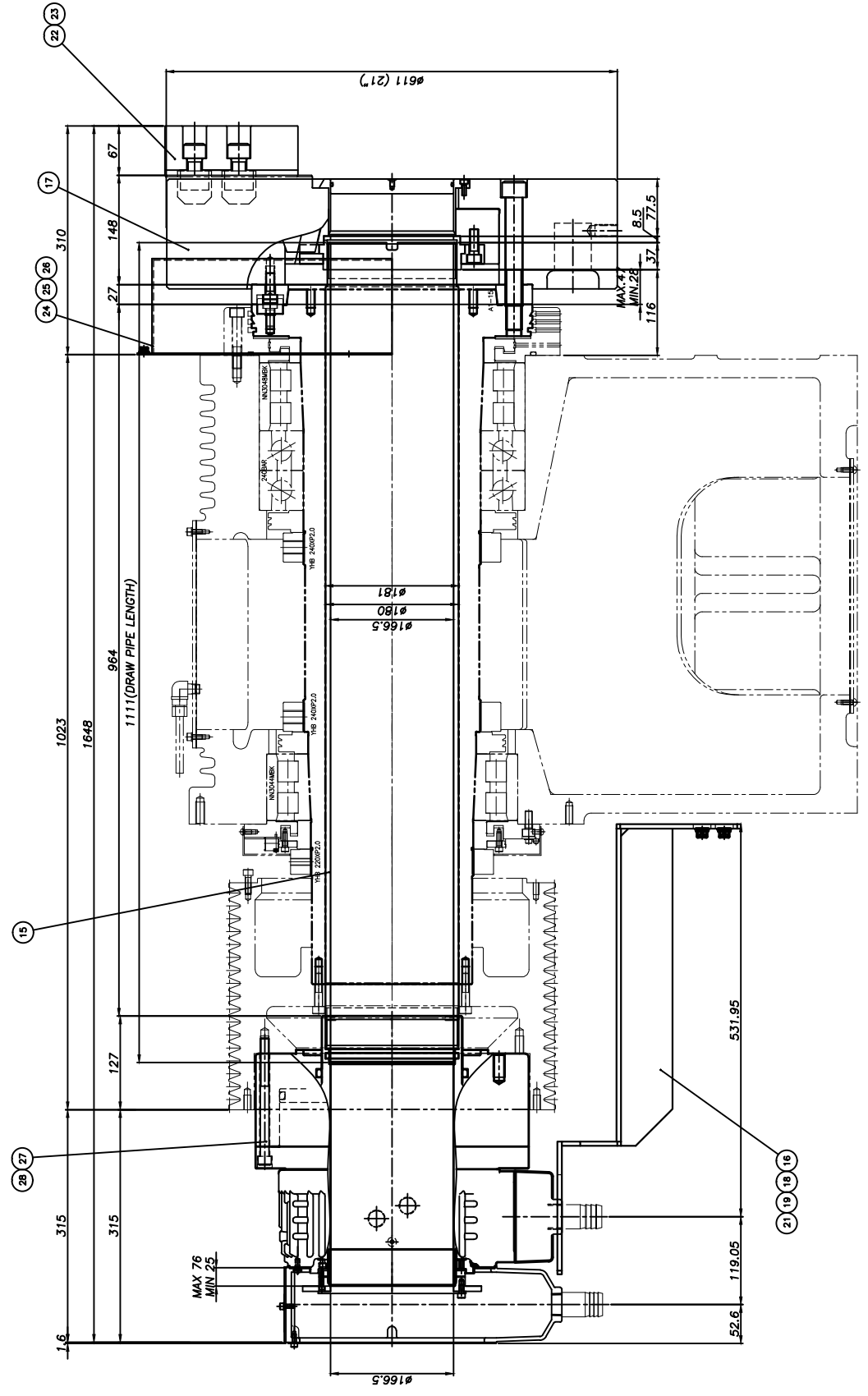

APP'D	JWS/HM	GENERAL TOLERANCE	HEAT TREATMENT
19/04/11		FINISHING	
		0.5 - 6 0H	
		6 -30 0E	
		36 125±0.3	
		120 315±0.5	
		315 1000±0.8	
		1000 2000±1.2	
		UNLESS OTHERWISE SPECIFIED	
		CHUCK ASSY	
		PLATING	
		SCALE	1/3.5
		UNIT ASSY	NAME
		NL5000	CHUCK ASSY
			CHUCK ASSY
			SCALE
			1/3.5
			1/1

MARK	REVISION	DATE	REV'D	CHK'D	MARK	REVISION	DATE	REV'D	CHK'D

APP'D	JWS/HM	GENERAL TOLERANCE	HEAT TREATMENT
19/04/11		FINISHING	
		0.5 - 6 0H	
		6 -30 0E	
		36 125±0.3	
		120 315±0.5	
		315 1000±0.8	
		1000 2000±1.2	
		UNLESS OTHERWISE SPECIFIED	
		CHUCK ASSY	
		PLATING	
		SCALE	1/3.5
		UNIT ASSY	NAME
		NL5000	CHUCK ASSY
			CHUCK ASSY
			SCALE
			1/3.5
			1/1